

Claire



nicoline

Descrizione modello - *Model Description*

Dimensioni - *Dimensions*

Composizioni consigliate - *Recommended compositions*

nicoline.it

ITALY - C.da Parchi Calia sn Z.I. - 70022 Altamura – BA - Telefono: +39 080 3101487

UNITED STATES - Nicoline Salotti Inc. po box 38783 - Greensboro – NC 27438 - Phone: +1 (336) 259 9881

SINGAPORE - 23 Genting Road #06-01 - Chevalier House Singapore 349481 - Telefono: +65 8168 3354

CLAIRE

Design Application n° 40202000002749

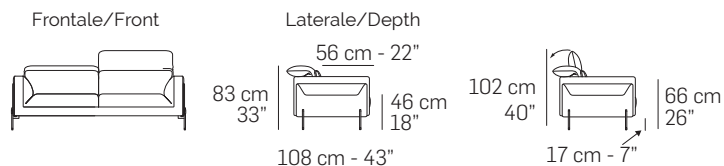

Caratteristiche standard

- Struttura in legno e multistrato, molleggio seduta e spalliera con cinghie elastiche.
- Imbottiture in poliuretano espanso ecologico a cellula aperta con densità differenziate.
- Rivestimento in pelle o tessuto. Tutti i rivestimenti sono fissi.
- Tutte le versioni contrassegnate dal simbolo "↑", sono dotate di poggiatesta regolabile manualmente.
- Piede in metallo Canna di fucile (Cod.50), Bronzo anticato (Cod.52).
- Elementi Cod.1421- 1422 - 1671 - 1672 - 3031 - 3032 con ripiano in marmo Emperador (Cod.EM) oppure marmo bianco Carrara (Cod.CA).
- Cucitura Cod.06 per rivestimento in pelle, nella parte superiore della seduta. Parti restanti con cucitura Cod.03.
- Cucitura Cod.03 per rivestimento in tessuto.
- Inserimento letto non possibile.
- Lato componibile rifinito.

Caratteristiche optional su richiesta senza maggiorazione

- Disponibile con cucitura a contrasto, per la scelta del colore fare riferimento ai codici del campionario pelli.

Caratteristiche optional su richiesta con maggiorazione

- Pannello esterno scocca bracciolo con rivestimento differente rispetto al resto del divano (Config.1).
- Per il multi rivestimento, tranne il pannello bracciolo che ha maggiorazioni dedicate, il prezzo va incrementato del 7%. Per maggiori dettagli fare riferimento al paragrafo "NOTE" posto nelle prime pagine del listino.

Note

- I disegni grafici che riportano l'asterisco (*) sono sempre con lato rifinito e anche agganciabili agli elementi componibili.
- Non è possibile applicare altre cuciture.
- Per alcuni tessuti e velluti l'azienda si riserva di applicare la cucitura Cod.00 / Cod.03 (vedi immagine).

Standard features

- Frame: wooden structure, seat suspensions in reinforced elastic webbing.
- Paddings in eco-friendly open cell polyurethane foam, with different densities.
- Covering in leather or fabric. Not removable coverings.
- All the versions marked by the symbol "↑" are equipped with manual adjustable headrest.
- Legs in Gunmetal (Cod.50), Antique Bronze (Cod.52).
- Versions Cod.1421- 1422 - 1671 - 1672 - 3031 - 3032 with top in marble Emperador (Cod.EM) or White Carrara marble (Cod.CA).
- Stitching type Cod.06 for leather covering for the top of the seat cushion. Stitching type cod.03 for the other parts.
- Stitching type Cod.03 for fabric covering.
- Folding bed not available.
- Sectional sides are finished.

Optional features available upon request with no upcharge

- Stitching, unless differently requested, will be matching the leather or fabric colour. Contrast stitching colour can be ordered at no extra charge. You might use as reference any Nicoline leather.

Optional features available upon request with an upcharge

- External panel of the armrest frame with a different covering from the rest of the sofa (Config. 1).
- 7% upcharge for combined coverings (except for the armrest panel which has dedicated upcharge). Please refer to the NOTES at the beginning of pricelist.

Notes

- Versions with asterisk (*) have always the terminal side finished with the possibility to be connected to modular elements.
- Different stitchings not available.
- For some fabrics and velvets production dept. must apply the stitching Cod.00 / Cod.03 (as per picture below).



Piede in metallo // Metal leg



Canna di Fucile (Cod.50) // Gunmetal (Cod.50)

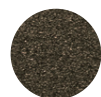

Bronzo Anticato (Cod.52) // Antique Bronze (Cod.52)



Elementi // Versions

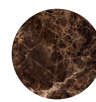

Marmo Emperador (Cod.EM) // Emperador Marble (Cod.EM)



Marmo Bianco Carrara (Cod.CA) // White Carrara Marble (Cod.CA)

Cuciture // Stitching

Pelle // Leather

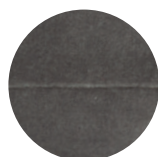

Cod.00

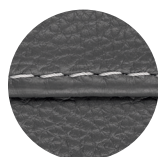

Cod.03

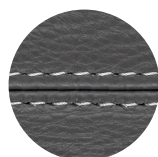

Cod.06



Spalliere dotate di poggiatesta regolabile manualmente // Backrests equipped with manually adjustable headrest Config. 1

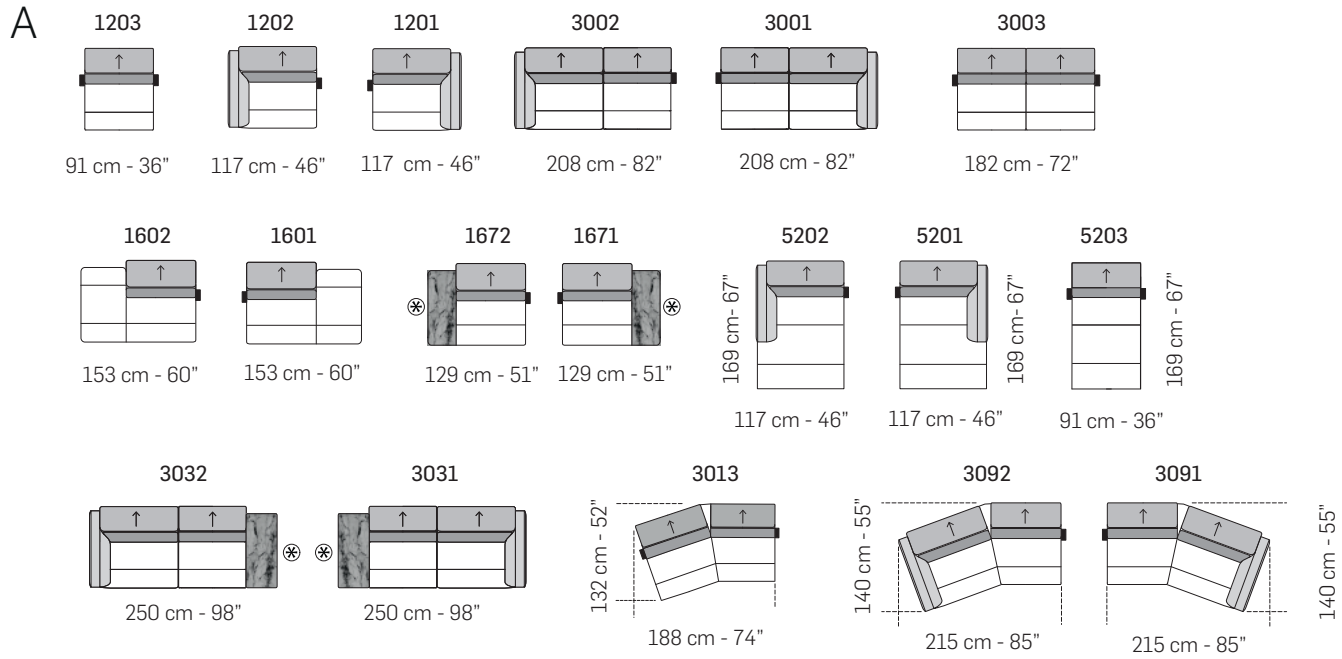
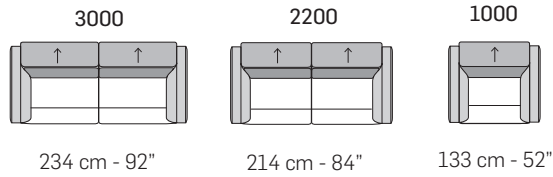

tutti gli elementi del gruppo A hanno lo stesso modulo di seduta - all items in group A have the same seat width

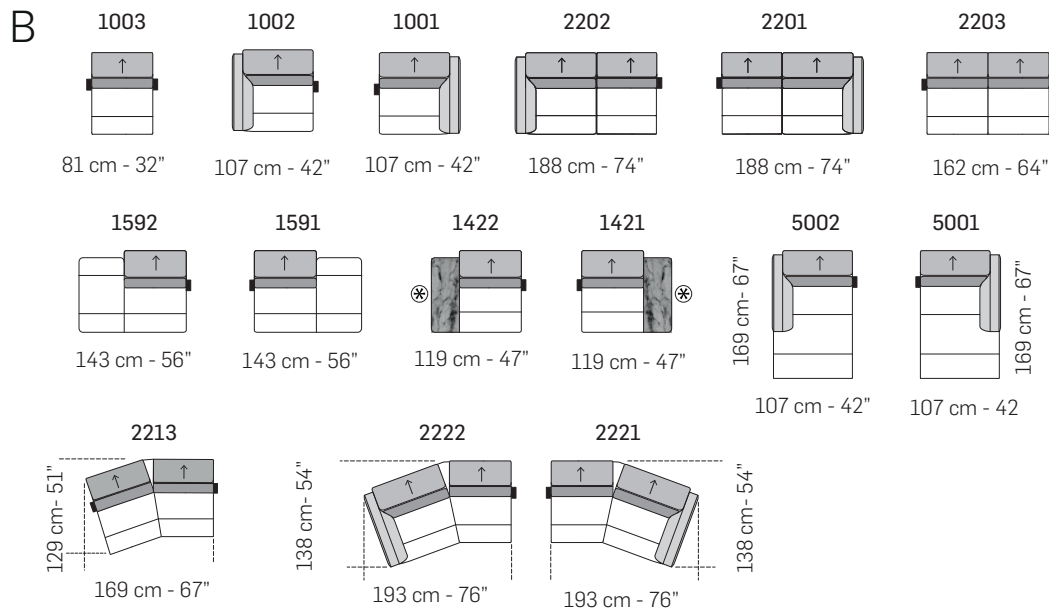

tutti gli elementi del gruppo B hanno lo stesso modulo di seduta - all items in group B have the same seat width

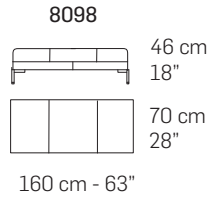
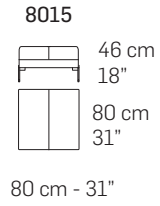
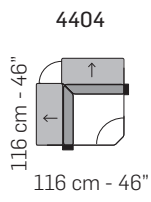

COMPOSIZIONI CONSIGLIATE / SUGGESTED COMPOSITIONS

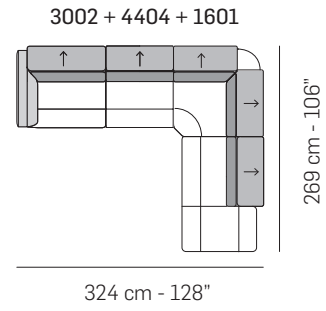
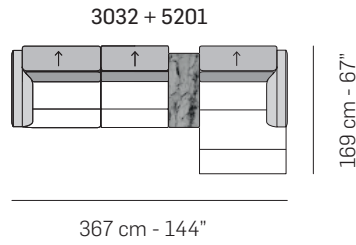
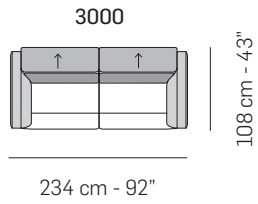

Scala 1:100
Ratio 1 to 100

Legenda / Legend

- Spalliera / Back Cushions
- Bracciolo / Armrest
- Marmo / Marble
- Poggiareni / Kidneyrest
- Seduta / Seat Cushions
- ↑ Poggiatesta regolabile / Adjustable headrest
- ⊗ Lato terminale sempre rifinito e agganciabile agli elementi componibili / Terminal side is always finished and it can also be connected to modular elements
- Aggancio Componibile / Connector

Note / Notes

Nicoline si riserva il diritto di apportare in ogni momento modifiche tecniche ed estetiche / Nicoline reserves the right to change, at any time and without prior warning, technical and aesthetic specifications of the articles.